

Haier

M7 HPWH R290 NEW 2024

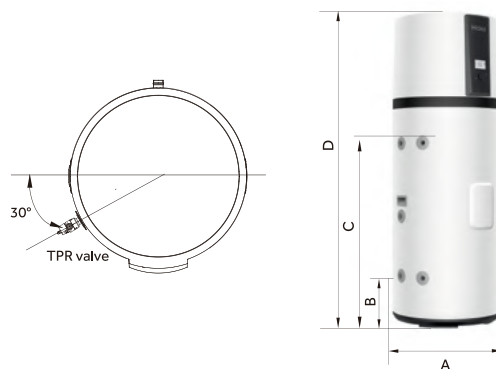

HP200M7-F9 - HP250M7-F9 - HP200M7C-F9 - HP250M7C-F9



Model	A	B	C	D
HP200M7-F9	620	270	980	1694
HP250M7-F9	620	270	1275	1989
HP200M7C-F9	620	270	980	1694
HP250M7C-F9	620	270	1275	1989

Unit: mm

The data in this catalogue is purely indicative as the data may vary. Please be advised to check the accuracy of the data with the supplier before purchasing products.

M7 TECHNICAL PARAMETERS

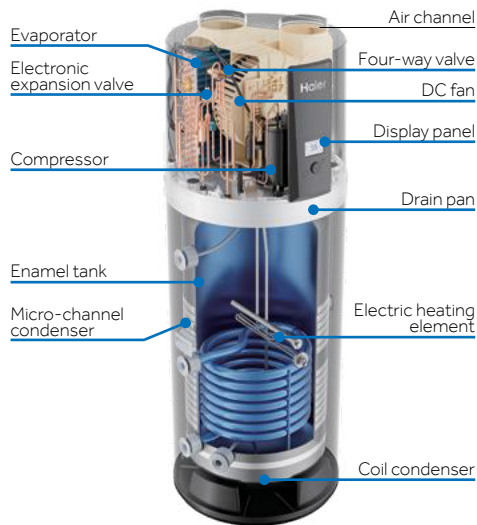

FEATURES

The R290 refrigerant offers excellent thermodynamic performance, allowing for higher water temperatures

Full inverter technology and micro-channel condenser, resulting in lower energy consumption and higher heating efficiency

Micro-channel condenser upgraded for R290 refrigerant

Dual power heating, enables faster hot water production

Equipped with a TFT screen and smart connectivity

Easy install

Model		HP200M7-F9	HP200M7C-F9	HP250M7-F9	HP250M7C-F9
Total cylinder capacity	L	194	185	250	240
Rated voltage/frequency	V/Hz	220-240/50	220-240/50	220-240/50	220-240/50
Tank Max pressure	bar	7	7	7	7
Thermal insulation	mm	50	50	50	50
Corrosion protection		Magnesium rod	Magnesium rod	Magnesium rod	Magnesium rod
Insulation protection rating		IPX4	IPX4	IPX4	IPX4
Performance					
COP@7°C(EN16147)		3.26	3.24	3.21	3.21
COP@14°C(EN16147)		3.50	3.50	3.45	3.45
Max air quantity	m ³ /h	300	300	300	300
Power input by electric backup	W	1500	1500	1500	1500
Rated power input by heat pump	W	320	320	320	320
Maximum power input by heat pump	W	535	535	535	535
Maximum power input	W	2035	2035	2035	2035
Heating water capacity	L/h	24	24	24	24
Heating up time(10°C/55°C)@7°C	h	7.8	6.71	10.51	10.09
Default temperature setting	°C	65	65	65	65
Temperature setting range-with heater	°C	35-75	35-75	35-75	35-75
Maximum temperature output for the heat pump only	°C	65	65	65	65
Refrigerant type/weight	kg	R290/0.15	R290/0.15	R290/0.15	R290/0.15
Noise power dB(A) @7°C	dB(A)	50	50	50	50
Sound pressure at 1m	dB(A)	36	36	36	36
V40 @7°C	L	234	229	313	314.4
Ambient temperature of heat pump	°C	-7-45	-7-45	-7-45	-7-45
Dimensions and connections					
Water inlet and outlet connection		Rp 3/4 Large Flow	Rp 3/4 Large Flow	Rp 3/4 Large Flow	Rp 3/4 Large Flow
TPR valve connection		Rp 3/4	Rp 3/4	Rp 3/4	Rp 3/4
Drain & water inlet connection		Rp 3/4	Rp 3/4	Rp 3/4	Rp 3/4
Product dimensions	(mm)	600 × 620 × 1694	600 × 620 × 1694	600 × 620 × 1989	600 × 620 × 1989
Packing dimension with pallet	(mm)	736 × 695 × 1940	736 × 695 × 1940	736 × 695 × 2250	736 × 695 × 2250
Net/gross weight	kg	86/109	96/119	98/121	107/131
Filled weight of the appliance	kg	281	282	345	348

*The COP and noise level data was tested in Haier lab.
The COP values obtained with external air temperature of 7°C and 14°C, inlet water temperature of 10°C and set temperature of 55°C (according to EN 16147).



Micro-Channel Condenser



Up to 65°C



Dual Power Heat



Child Lock



36dB



hOn Wifi

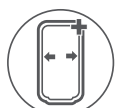

Enamel Tank

